

MOUNTING BRACKETS

MOUNTING BRACKETS

The Mounting bracket is the connector between the parent machine and the attachment. Digga manufactures mounting brackets to suit most skid steer loaders, backhoes, and excavators. Our skid steer mounting brackets feature a slide cradle which allows the user to offset the drive head, allowing for drilling close to structures.

MOUNTING BRACKET TYPES

Digga manufacture a range of brackets up to 80t excavators. Configurations include double pin, fixed, and loose pin, as well as the Digga developed Ryno (Piling) Hitch for larger drives.

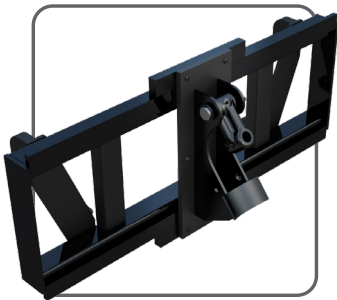

**AGRICULTURAL
LOADER MOUNT**

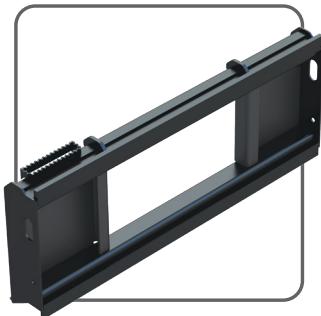

**SIDE SHIFT
SKID STEER MOUNT**



**FIXED
SKID STEER MOUNT**



**DOUBLE PIN
EXCAVATOR MOUNT
(FIXED AND LOOSE)**



**SINGLE PIN
EXCAVATOR MOUNT**



**AGRICULTURAL BUCKET
SIDE MOUNT**

RYNO (PILING) HITCH

The Ryno (Piling) Hitch was designed by Digga to make it easier to connect large augers and anchors to an auger drive. Using a Ryno (Piling) Hitch will eliminate the costly need for a crane to connect piling tools to your auger drive.

Specifically designed to handle the torsional loads of anchors and screw piling. The Ryno (Piling) Hitch allows the operator to cradle the drive up to a 90 degree angle for easy connection to augers or anchors. Suits Supa Drives, Mega Drives, Ultra Drives, and Xtreme Drives.

FEATURES

- Extra heavy duty, fully engineered design
- Premium grade steel
- Highly efficient, compact design
- Cradle stops auger drives and anchors from swinging whilst maneuvering over uneven terrain



RYNO (PILING) HITCH

